

Comparative assessment of bone stress associated with miniplates and mini-implants used for orthodontic anchorage: A finite element study

Satyabrata Das^{1,*}, Goutham N.², Nitin R. Khargekar³, Arora Chiragkumar K.⁴

¹Assistant Professor, New Horizon Dental College & Research Institute, Bilaspur, ²Reader, ⁴P.G. Student, Dept. of Orthodontics, Vokkaligara Sangha Dental College, Bangalore, ³Assistant Professor, Sri Venkateshwara Dental College & Hospital, Bangalore

***Corresponding Author:**

Email: sea.hawk7@gmail.com

Abstract

Objective: To assess and compare bone stress associated with various miniplates and mini-implant systems by using finite element analysis.

Materials and Methods: Bone stress associated with various miniplate and mini-implant systems were compared and assessed by using finite element analysis and taking into account a number of variables, which play an important role in the success, and failure of such TAD systems.

Results: Peak von Mises stresses in cortical and cancellous bones for Miniplate Base Model are 18.43 MPa and 1.735 MPa respectively and for Mini-Implant Base Model are 1.621 Mpa and 0.2645 MPa respectively.

Conclusion: Bone stress due to miniplate is more compared to mini-implant. Bone stress decreases with increased cortical thickness, increases with increased force magnitude. Highest bone stress is due to I-type followed by L-type, Y-type and T-type miniplate. Increased miniplate fixation screw length for miniplate or mini-implant length doesn't have significant effect on bone stress. Bone stress decreases as mini-implant diameter increases.

Keywords: Miniplate, Mini-implant, Bone Stress, Finite Element Analysis.

Introduction

The conservation, diminution of anchorage, and its repercussion on the treatment planning have been a major topic of study in Orthodontics since many years. By now the observant reader and experienced orthodontists couldn't prevent all reciprocal treatment effects (or anchorage loss) by conventional means.

Hence, experiments were initiated to conserve anchorage by taking help from skeletal bone. Due to lack of success in many such experiments, all hopes to use this method to conserve anchorage seems to have faded until Creekmore and Eklund revisited it in the year 1983.⁽¹⁾ After that, subsequent case reports and studies have clearly demonstrated that teeth can be moved without undesired effects on other groups of teeth when skeletal anchorage is employed and hence temporary skeletal anchorage devices were rapidly developed thereafter. The three most commonly used temporary skeletal anchorage devices nowadays are: a) palatal implants, b) miniscrews, and c) miniplates.⁽²⁾

A study was done to check for the survival and failure rates of various TADs. The failure rates for miniplates, palatal implants and miniscrews were found to be 7.3%, 10.5 % and 16.4% respectively.⁽³⁾ According to Motoyoshi, et al, the development of a bone stress around the mini-implant is reportedly correlated with mini-implant failure.⁽⁴⁾

Development of stress in supporting tissues like bone in response to force applied during treatment is inevitable. But too much stress can be considered as a bad prognostic factor. With the advent of modern sophisticated software, complex biomechanical research

and analysis in dentistry is now possible with the help of finite element modeling.⁽⁵⁾

Therefore, the purpose of this study was to assess and compare bone stress associated with various miniplate and mini-implant systems by using finite element analysis and taking into account a number of variables, which play an important role in the success, and failure of such TAD systems.

Materials and Methods

Three-dimensional model of bone block consisting of cortical and cancellous bone with the dimension of 30 mm length, 30 mm width and 25 mm height was made. To study the effect of cortical thickness, 5 values were simulated: 0.25, 0.5, 0.75, 1.0 & 1.5 mm. Three-dimensional CAD models of the miniplates, the insertion screw and the mini-implant were created using CATIA V5 R21 software. The miniplate and insertion screw geometries were based on the Mondeal System (Tuttlingen, Germany). Four types of plates: L – type, T – type, Y – type & I – type with three screw lengths of 5, 7 & 9 mm were modeled. The fixation screw had a thread profile that consisted of an isosceles triangle of 0.4 mm in height and 0.16 mm at the base, with a thread pitch of 1.0 mm. The mini-implant geometries are based on ISA orthodontic implant (Biodent, Tokyo, Japan). Three lengths (6, 8, & 10 mm) and two diameters (1.6 & 2.0 mm) were modeled.

In particular 4-noded 3D tetrahedral elements were used for discretizing the complete assembly. Fine mesh was used where highly complex and intricate geometry was required to be captured. Second order tetrahedral elements were used for discretizing the bone, miniplate

and its screw, mini-implant. Finite element model was thus created and used for analysis in the present study.

Quality check was done which included check for skewness, aspect ratio and Jacobian values. The process was repeated to obtain the best quality mesh for further analysis. The final finite element model was thus built.

All materials in the model were considered homogeneous, isotropic, and linearly elastic. The miniplate, fixation screw, and mini-implant were assumed to be made of pure titanium. Mechanical properties such as Young's modulus and Poisson's ratio of the bone block, miniplate assembly and mini-implant were assigned to the finite element model. Table 1 shows the mechanical properties (linear elastic properties) used for different components that formed the finite element model.^(4,6)

Table 1

Materials	Young's Modulus (MPa)	Poisson's ratio	Mass Density (g/cm ³)
Titanium	110000	0.3	4.5
Cortical Bone	13700	0.3	1.8
Cancellous Bone	300	0.3	0.8

After meshing of the model, mechanical properties, boundary conditions or constraints were applied on to the finite element model. To determine the loading effect, 3 force magnitudes (2, 4, and 6 N) were used in both mini plate and mini-implant system and 2 force directions (in-plane force and off-plane force) were investigated. The in-plane force was defined as when the loading force vector was lying on the plate plane, the x-z plane. The z-axis was determined as the axis of the plate's long arm, whereas the x-axis was perpendicular to the z-axis, with the plate plane pointing in the direction of the short arm of the L- type plate. The y-axis was determined by the cross-product of the z-x axis in right coordinate system, and the y direction correspondingly was normal to the superior surface of the bone block. For the first loading group (in-plane force; $y = 90^\circ$), 3 loading modes were evaluated: forward bending ($x = 0^\circ$), tensile force ($x = 90^\circ$), and backward bending ($x = 180^\circ$). For the second loading group (off-plane force), 3 loading modes were investigated involving a y force component added into the in-plane forward bending force ($x = 0^\circ$). This created force directions with respect to the y-axis of 60° (downward), 90° (no downward and no upward force), and 120° (upward). After applying loads and constraints, ABAQUS 6.14 was used for Finite Element Analysis. von Mises stresses for different cases were then tabulated for different components.

The stress distribution pattern was analyzed and results are represented graphically and tabulated.

Results

A base model of bone block was designed to have a 1 mm of cortical bone thickness. L -type miniplate was

used for the assembly with two fixation screws of 5 mm length each. The mini-implant used for the assembly had a dimension of 1.6 mm diameter and 8 mm length. Both the assemblies were subjected to 4 N of forward bending force ($x=0^\circ, y=90^\circ$). Table 2 shows peak von Mises stresses in the Miniplate and Mini-Implant base models. The peak von Mises stress values in cortical bone for Insertion Screw Lengths of 5mm, 7mm and 9mm are 18.43 MPa, 18.42 MPa and 18.40 MPa respectively. The peak von Mises stress values in cancellous bone for Insertion Screw Lengths of 5mm, 7mm and 9mm are 1.735, 1.209 and 1.212 respectively. The peak von Mises stress values in cortical bone for Mini-Implant lengths of 6mm, 8 mm and 10mm are 3.252 MPa, 3.309 MPa and 3.281 MPa respectively. The peak von Mises stress values in cancellous bone for Mini-Implant lengths of 6mm, 8mm and 10mm are 0.342 MPa, 0.335 MPa and 0.328 MPa respectively.

Following are the peak von Mises stress values in cortical bone due to Miniplate with 4 N force and different directions. For the 'in plane' force directions of ($X=0^\circ, Y=90^\circ$), ($X=90^\circ, Y=90^\circ$) and ($X=180^\circ, Y=90^\circ$), the peak von Mises stress values in cortical bone are 18.43 MPa, 0.9981 MPa and 18.43 MPa respectively. For the 'off plane' force directions of ($Y=60^\circ, X=0^\circ$), ($Y=90^\circ, X=0^\circ$) and ($Y=120^\circ, X=0^\circ$), the peak von Mises stress values in cortical bone are 12.03 MPa, 18.43 MPa and 13.26 MPa respectively.

Following are the peak von Mises stress values in cortical bone due to Mini-Implant with 4 N force and different directions. For the 'in plane' force directions of ($X=0^\circ, Y=90^\circ$), ($X=90^\circ, Y=90^\circ$) and ($X=180^\circ, Y=90^\circ$), the peak von Mises stress values in cortical bone are 1.621 MPa, 1.671 MPa and 1.621 MPa respectively. For the 'off plane' force directions of ($Y=60^\circ, X=0^\circ$), ($Y=90^\circ, X=0^\circ$) and ($Y=120^\circ, X=0^\circ$), the peak von Mises stress values in cortical bone are 1.377 MPa, 1.621 MPa and 1.345 MPa respectively.

Table 2: Peak von Mises stresses in the Miniplate and Mini-Implant base models

Region	Bone Stress due to Miniplate (MPa)	Bone Stress due to Mini-Implant (MPa)
Cortical Bone	18.43	1.621
Cancellous Bone	1.735	0.2645

Table 3: Peak von Mises stresses for different cortical bone thickness

Cortical Bone Thickness (mm)	Bone Stress due to Miniplate (MPa)		Bone Stress due to Mini-Implant (MPa)	
	In Cortical bone	In Cancellous bone	In Cortical bone	In Cancellous bone
0.25	41.23	2.967	1.218	0.4367
0.5	34.17	3.030	1.190	0.3355
0.75	28.56	2.478	1.159	0.2249
1.0	18.43	1.735	1.051	0.2645

1.5	13.92	1.004	1.039	0.1769
-----	-------	-------	-------	--------

Table 4: Peak von Mises stresses for different Force magnitudes

Magnitude of Force (N)	Bone Stress due to Miniplate (MPa)		Bone Stress due to Mini-Implant (MPa)	
	In Cortical bone	In Cancellous bone	In Cortical bone	In Cancellous bone
2	9.22	0.8675	0.81	0.1323
4	18.43	1.735	1.621	0.2645
6	27.66	2.6025	2.431	0.3967

Table 5: Peak von Mises stress values in cortical and cancellous bone due to different shapes of Miniplate

Region	Bone stress due to Miniplate (MPa)			
	L- type	I- type	Y- type	T- type
Cortical Bone	18.43	19.57	15.72	13.09
Cancellous Bone	1.735	1.826	1.93	1.138

Table 6: Peak von Mises stress values in cortical and cancellous bone due to 8 mm length Mini-Implant with different diameters

Mini-Implant Diameter (mm)	Stress in Cortical Bone (MPa)	Stress in Cancellous Bone (MPa)
1.6	3.309	0.335
2.0	1.747	0.194

Discussion

A number of factors are responsible for the stability, survival and failure rates of TADs. Various factors like peri-implant inflammation, bone parameters, insertion variables, thread shape, screw diameter, etc. have been linked to their failures.

Development of stress in supporting tissues like bone in response to force applied during treatment is inevitable. The clinical success of an implant is dependent on the fact that the stresses, which are generated in the bone due to application of force on an implant, are not of such a magnitude that would endanger the life span of the implant.

With the advent of modern and sophisticated software, complex biomechanical research and analysis in dentistry is now possible with the help of finite element modeling. The objectives of this study were to assess and compare bone stress associated with loading of various miniplate and mini-implant systems along with its surrounding osseous structure by using finite element analysis and taking into account a number of variables, which play an important role in the success, and failure of such TAD systems.

Table 2 shows peak von Mises stresses in the Miniplate and Mini-Implant base models. According to the table, Peak von Mises stresses in cortical and cancellous bones for Miniplate base model are way

higher than those for the Mini-Implant base model. No study was conducted in the past to compare the peak von Mises stress between miniplate and mini-implant. Rather, separate FEM stress studies were done for miniplates and mini-implants.^(2,4,5)

Fig. 1 and 2 show the distribution of von Mises stress in all the elements of the base model of Miniplate. Under the forward bending force, the largest peak of von Mises stress occurred in the bone plate with the long arm of the bone plate under bending mode. First screw had the higher peak von Mises stress of the two screws and it was located at the screw heads. The peak stress in the cortex and cancellous bone was found under the screws. The results obtained are consistent with a similar study done by Huang, et al.⁽²⁾

The distribution of von Mises stress in the base model of Miniplate

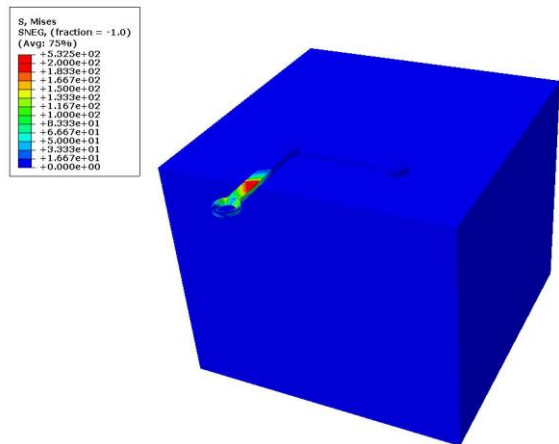

Fig. 1: (a) All components

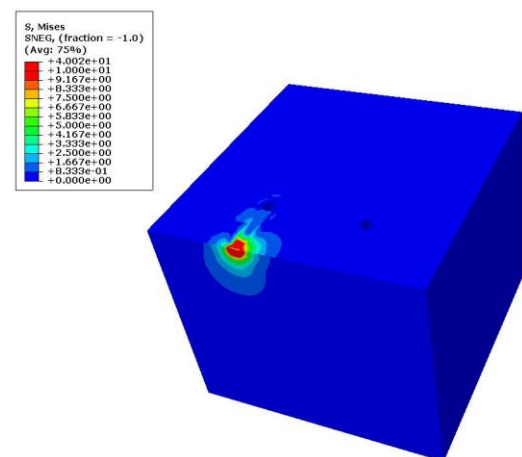

Fig. 1: (b) Cortical Bone

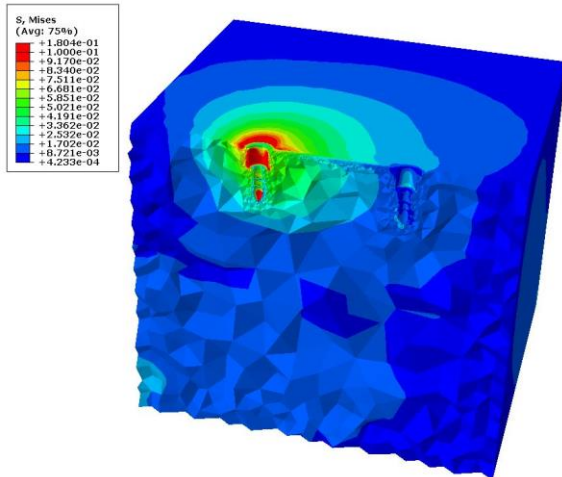

Fig. 1: (c) Cancellous Bone

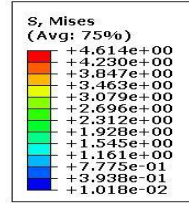

Fig. 2: (c) Screw 2

The distribution of von Mises stress in the base model of Miniplate

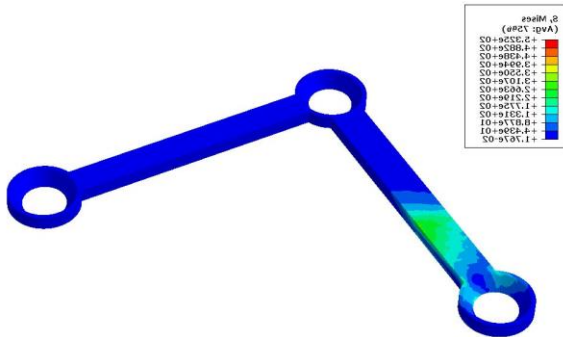

Fig. 2: (a) Miniplate

Fig. 3 shows the distribution of von Mises stress in all the elements of the base model of Mini-Implant. The results showed the neck region of mini-implant to have experienced the peak stress. And the peak stress in cortex occurred around the edge of top surface. Two sites were created in the bone due to the application of forward bending force. The side where implant was touching the cortical bone in the direction of force created a compression site and the opposite side where the implant was touching the cancellous bone created a tension site. Hence the areas for peak stress in the cortical and cancellous bone. The results in this study were in accordance to similar studies done.⁽⁷⁾

The distribution of von Mises stress in the base model of Mini-Implant

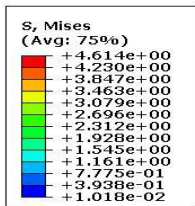

Fig. 2: (b) Screw 1

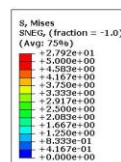

Fig. 3: (a) Cross-section View of all components

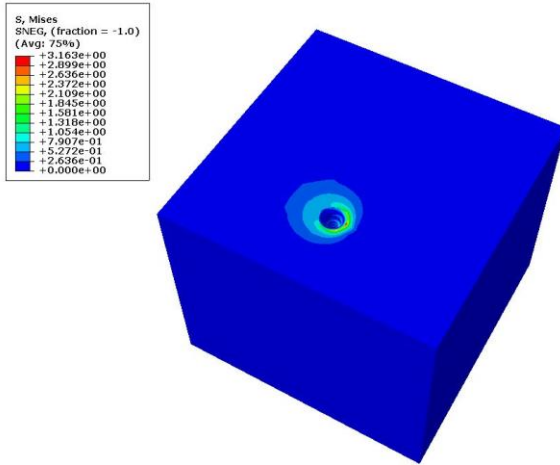

Fig. 3: (b) Cortical Bone

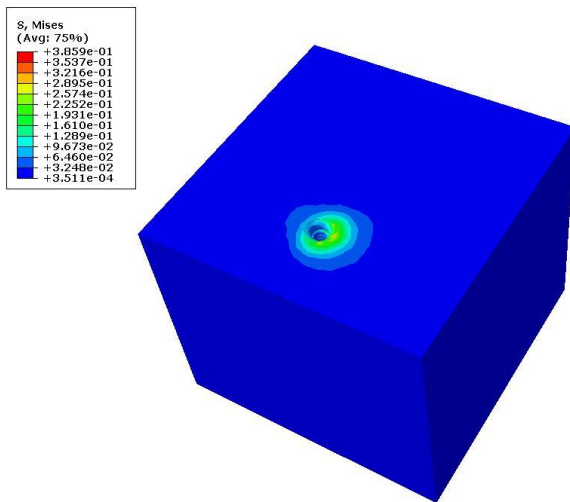

Fig. 3: (c) Cancellous Bone

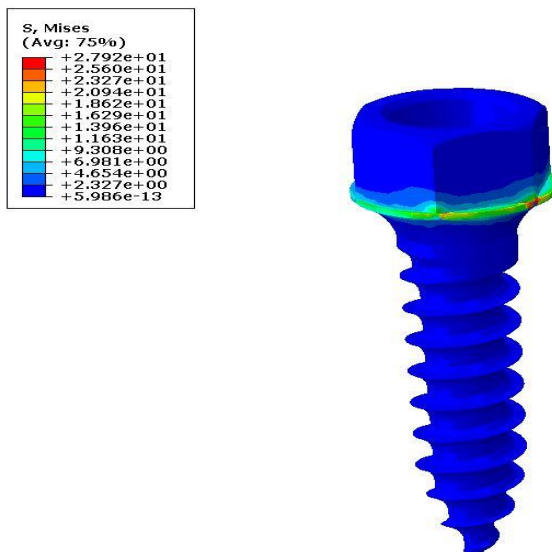

Fig. 3: (d) MiniImplant

According to Table 3, peak stresses in cortical and cancellous bones for Miniplate base model are significantly higher than those for the Mini-Implant base model. No study was conducted in the past to compare the peak von Mises stress between miniplate and mini-implant due to varying cortical bone thickness. The lowest peak von Mises stress occurred with the 1.5 mm model and as the cortex thickness decreased, the stress values increased.

In our study there was minimal effect of cortical bone thickness on the peak von Mises stress values on cortical bone due to mini-implant placement. Similar results were found by Liu,⁽⁷⁾ Duaibis,⁽⁸⁾ and Motoyoshi.⁽⁹⁾

Under varying force magnitudes, Table 4 shows that peak stresses in cortical and cancellous bones for Miniplate base model are significantly higher than those for the Mini-Implant base model. No such study was conducted in the past. Both miniplate and mini-implant exhibited linear increment of stress values as the force magnitude increased. This can be explained by the fact that the material properties used for the components of the study were assumed to be homogeneous, isotropic, and linearly elastic. The clinical implication of the result can be presumed that higher loading force should be avoided for the longevity of the TAD.

Peak stress values in cortical bone due to miniplate with 4 N force and different directions infers that, for the in-plane force directions, the stress was least for the tensile mode ($X=90^{\circ}$, $Y=90^{\circ}$). In a clinical setup, this tensile force can be presumed to be equivalent to the intrusive force used. The stress generated due to forward bending and backward bending force was equal in magnitude. This can be explained by the fact that the miniplate was acted upon by two forces that were equal in magnitude but opposite in direction.

For the off plane force direction, the stress values for upward and downward bending were lesser compared to the forward bending force. This can be explained by the fact that upward or downward bending force gets divided into a horizontal component and a vertical component. Horizontal component of force imparts more stress than the vertical component. Hence horizontal forces should be avoided or minimized to reduce stress.

Peak stress values in cortical bone due to Mini-Implant with 4 N force and different directions infer that the stress on the cortex of the miniscrews had the greatest values with a force direction of 90° in this study. This force direction was a pure bending load, whereas the force directions of 60° and 120° had both the horizontal component and the vertical component. As explained earlier, the horizontal component has more say in such a situation, the bone stress was lesser compared to the 90° force. This supports the results obtained by Liu⁷ and Sütpideler.⁽¹⁰⁾

According to Table 5, the bone stress was highest for I- type plate followed by L- type, Y- type and T- type.

This can be explained by the fact that the screws in the I – type were arranged in a vertical fashion whereas the screws in the L, Y and T were arranged horizontally. Hence, the stress developed due to I- type was highest. When comparing the L- type with Y or T- type had lesser stress because the latter had shorter arms, which had more symmetrically placed screws. Findings in this study are in accordance with similar findings by Veziroglu.⁽¹¹⁾

There were no significant changes in the stress values when insertion screw length of miniplate assembly was varied.

There were no significant changes in the stress values when mini-implant length was varied while keeping the diameter constant. This supports the results derived by Miyawaki.⁽¹²⁾

Table 6 shows that when the length of the implant is kept constant, the bone stress values decreased peak as the implant diameter increased. This supports the result found by Liu⁽⁷⁾ and Duaibis.⁽⁸⁾

There were certain limitations in this study. The geometry of the bone block was modeled to a simple cuboid. The materials used in the study were assumed to be homogeneous, isotropic, and linearly elastic. The interface of bone and TADs was assumed to be fully bonded and the interface between the bone and the TADs was frictionless contact. Bone quality of cancellous bone was not taken into account to prevent bone quality potentially invalidating the outcomes related to other relevant factors. Nonetheless, these limitations should affect the quantitative values of the simulations, not the underlying bio-mechanism. Many factors considered in this study hold importance in a clinical scenario.

Conclusion

Based on the finite element study, following conclusions were drawn –

- Bone stress was significantly higher for the miniplate system compared to mini-implant.
- The stress induced on cancellous bone was much lower than that on the cortex.
- The largest peak of von Mises stress occurred in the bone plate and the peak stress of the bone plate was concentrated under the first miniscrew. For both screws, the peak stress occurred at the screw head.
- The maximum von Mises stress in the mini-implant occurred at the neck region.
- Bone stress decreased as the cortical thickness increased in case of miniplates and mini-implants, but the changes seen in mini-implants were mild.
- Bone stress showed a linear increment with increase of force magnitude, both for miniplate and mini-implant.
- Bone stress due to tensile loading was minimum for miniplate and maximum for mini-implant.
- Bone stress due to changes in the insertion screw length of miniplate was less significant.

- Bone stress for the various geometries of miniplates decreased in the following order: I-type > L-type > Y-type > T-type.
- There were no significant changes in the bone stress values when mini-implant length was varied.
- Bone stress decreased as the mini-implant diameter was increased.

References

1. Creekmore TD, Eklund MK. The possibility of skeletal anchorage. *J Clin Orthod* 1983;17(4):266-269.
2. Huang YW, Chang CH, Wong TY, Liu JK. Bone stress when miniplates are used for orthodontic anchorage: Finite element analysis. *Am J Orthod Dentofacial Orthop* 2012;142(4):466-472.
3. Schätzle M, Männchen R, Zwahlen M, Lang NP. Survival and failure rates of orthodontic temporary anchorage devices: a systematic review. *Clin Oral Implants Res* 2009;20(12):1351-1359.
4. Motoyoshi M, Ueno S, Okazaki K, Shimizu N. Bone stress for a mini-implant close to the roots of adjacent teeth—3D finite element analysis. *Int J Oral Maxillofac Surg* 2009;38(4):363-368.
5. Lin TS, Tsai FD, Chen CY, Lin LW. Factorial analysis of variables affecting bone stress adjacent to the orthodontic anchorage mini-implant with finite element analysis. *Am J Orthod Dentofacial Orthop* 2013;143(2):182-189.
6. Gracco A, Cirignaco A, Cozzani M, Boccaccio A, Pappalettere C, Vitale G. Numerical/experimental analysis of the stress field around miniscrews for orthodontic anchorage. *Eur J Orthod* 2009;31(1):12–20.
7. Liu TC, Chang CH, Wong TY, Liu JK. Finite element analysis of miniscrew implants used for orthodontic anchorage. *Am J Orthod Dentofacial Orthop* 2012;141(4):468-76.
8. Duaibis R, Kusnoto B, Natarajan R, Zhao L, Evans C. Factors affecting stresses in cortical bone around miniscrew implants A three-dimensional finite element study. *Angle Orthod* 2012;82(5):875–880.
9. Motoyoshi M, Inaba M, Ono A, Ueno S, Shimizu N. The effect of cortical bone thickness on the stability of orthodontic mini-implants and on the stress distribution in surrounding bone. *Int J Oral Maxillofac Surg* 2009;38(1):13–18.
10. Sütçüder M, Eckert SE, Zobi M, An KN. Finite element analysis of effect of prosthesis height, angle of force application, and implant offset on supporting bone. *Int J Oral Maxillofac Implants* 2004;19(6): 819-25.
11. Veziroglu F, Uckan S, Ozden UA, Arman A. Stability of Zygomatic Plate-Screw Orthodontic Anchorage System A Finite Element Analysis. *Angle Orthod* 2008;78(5):902-907.
12. Miyawaki S, Koyama I, Inoue M, Mishima K, Sugahara T, Takano-Yamamoto T. Factors associated with the stability of titanium screws placed in the posterior region for orthodontic anchorage. *Am J Orthod Dentofacial Orthop* 2003;124(4):373-378.